

Mobility 56

Base Extension Kit with Casters

The Mobility 56 kit adds mobility to any IQAir compact room air cleaning system. In addition, it optimises the air circulation patterns by raising the air intake of the IQAir system off the ground.

The four casters feature a soft rubber lining to ensure smooth movement and to protect hardwood, laminate, tile, slate and other hard floors. Two of the casters can be locked to prevent the IQAir system from being moved unintentionally.

The Mobility 56 can be fitted to any compact IQAir model in a matter of minutes without the need for tools.

Fitting Instructions

Important: Remove cartridges from GC/GCX/Dental systems prior to installing the Mobility 56.

1. Remove wing screws (with washers) from the base extension rails.
2. Lay the IQAir system carefully on its side and slide the base extension rails into the base of the system.
3. Fasten both extension rails to the base by inserting the wing screws (including washer) into the small rectangular cut-outs in the base.
4. When both extension rails are securely installed, carefully lift the entire air cleaning system up and place it on all four casters at once. (Caution: Do not bring the system into its upright position by pivoting it on just 2 casters as the system may slip away or the extensions may be bent under the weight of the IQAir system).

If mobility of the IQAir system is not required anymore or other IQAir accessories are to be installed to the base, the Mobility 56 can be simply removed.

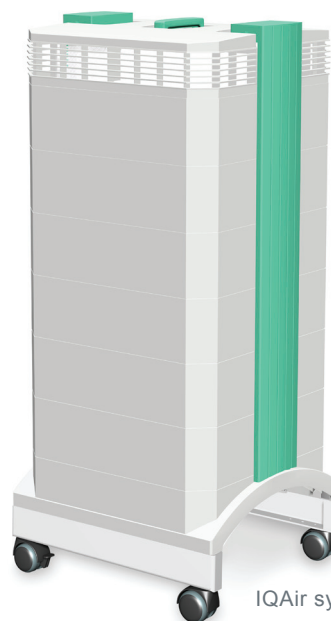
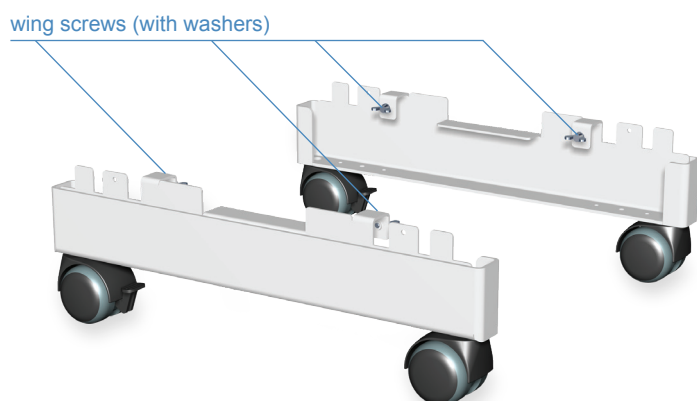

IQAir system
with Mobility 56 installed

Technical Specifications

Base extension blocks

Material: powder-coated steel
Colour: light grey

Casters

Material: ABS;
Colour: black/grey

Height

approx. 12 cm (4.7 inches)

Weight

approx. 2.5 kg (5.5 lbs.)

Compatible

with all compact IQAir models

Not Compatible

with the following IQAir accessories:
VM FlexVac™, FlexVac™, VM InFlow™, VMF™

Article No.:

210 40 00 10